

NOTES:

1 A POSITIVE GOING VOLTAGE AT TERMINAL 2, RELATIVE TO THE CENTER-TAP TERMINAL, OR A NEGATIVE GOING VOLTAGE AT TERMINAL 1, RELATIVE TO THE CENTER-TAP TERMINAL, CAUSES A DECREASE IN PRESSURE AT THE SOUND OUTLET.

2 LOCATED FROM TWO SURFACES FOR CUSTOMER CONVENIENCE. ONLY APPLICABLE FROM ONE SURFACE, NOT TO BE USED TOGETHER.

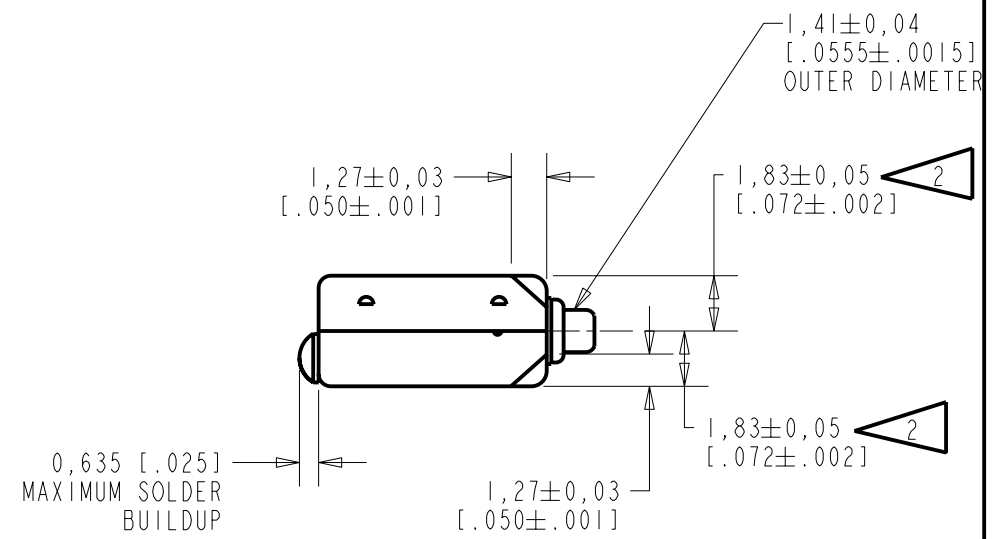
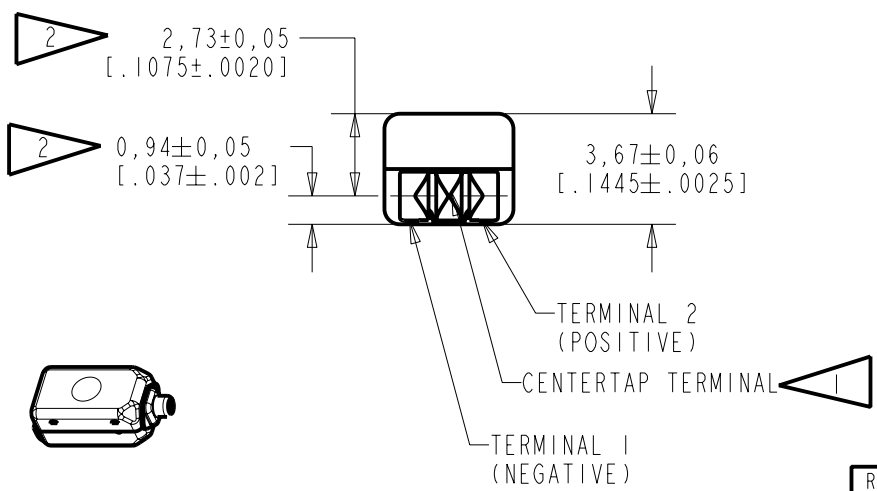

NOMINAL WEIGHT .42 GRAMS
DIMENSIONS IN MILLIMETERS [INCHES]

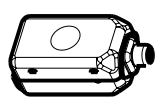

Revision	C.O. #	Implementation Date	RELEASE LEVEL	REVISION
B	CI0106330	9-3-07	Released	B
A	CI0103421	11-14-05		
SCALE: 4:1			DR. BY	DATE
DO NOT SCALE DRAWING			CRG	11-14-05
TITLE: RECEIVER			EC-23098-000	CK. BY
OUTLINE DRAWING			SHT 1.1	GJP
			APP. BY	DATE
			GJP	11-22-05

KNOWLES ELECTRONICS
ITASCA, ILLINOIS U.S.A.

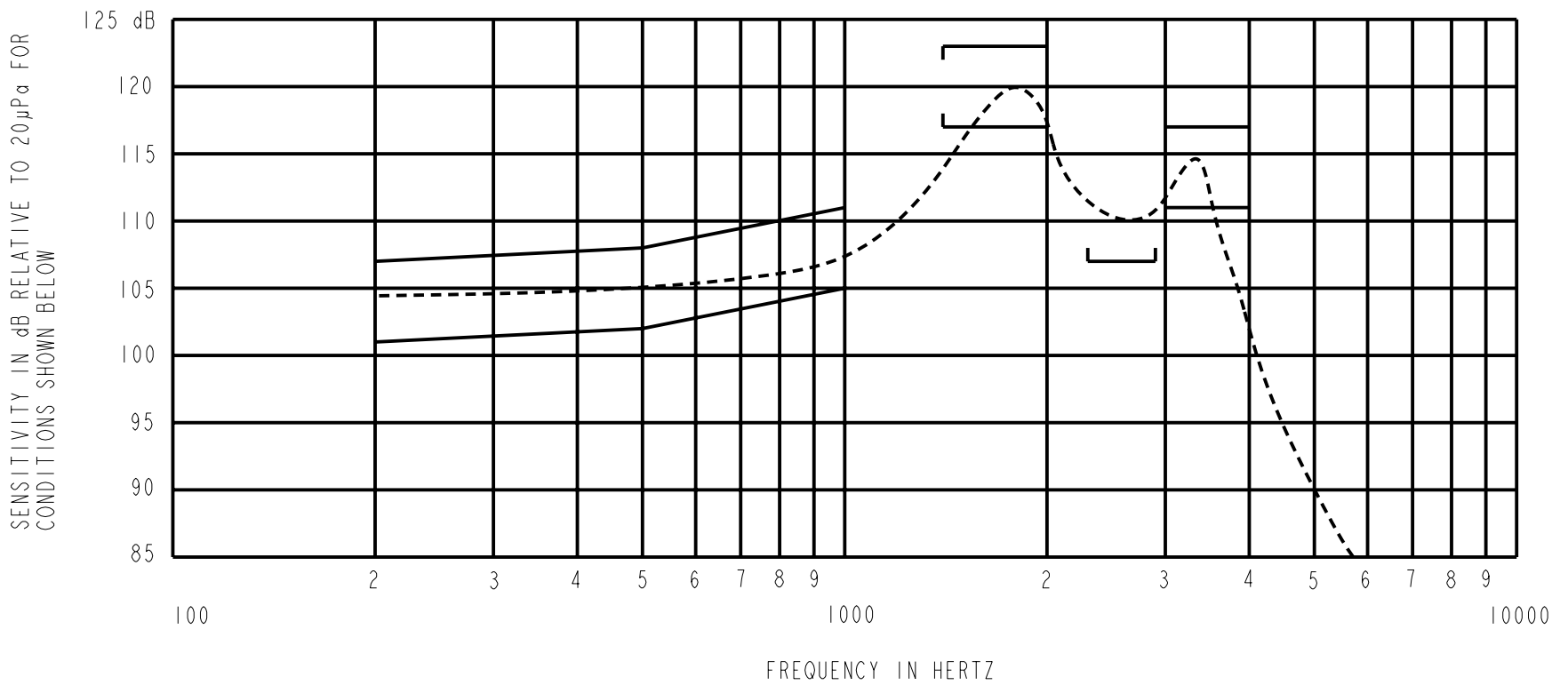

NOTES:

1. MEASUREMENTS MADE USING 10mm (.394") OF 1mm (.039") ID TUBE CONNECTED TO A SIMULATED ANSI S3.3-1971 TYPE HA-3 COUPLER. (T-3462)

2. SENSITIVITY

FREQUENCY	MIN.	MAX.
200	101.0	107.0
500	102.0	108.0
1000	105.0	111.0
1400-2000	117.0	123.0
2300-2900	107.0	---
3000-4000	111.0	117.0

- 3. RESPONSE, IMPEDANCE, AND DISTORTION MEASUREMENTS MADE USING THE ELECTRICAL TEST CONDITIONS SHOWN BELOW.
- 4. ELECTRICAL SOURCE IMPEDANCE MUST BE GREATER THAN 20 TIMES 1KHz IMPEDANCE FOR TEST CONDITIONS SHOWN BELOW.
- 5. INDIVIDUAL SPECIFICATIONS:

PORT LOCATION	IMPEDANCE OHMS ±15%		DCR @20°C OHMS ±10%	DISTORTION		ELECTRICAL TEST CONDITIONS	
	1KHz	500Hz		MAX. %	FREQ Hz	AC mA RMS	DC mA
12S	840	425	196	10	800	0.77	0.00

Revision	C.O. #	Implementation Date	RELEASE LEVEL	REVISION
B	C10106330	9-3-07	Released	B
A	C10103421	11-14-05		

KNOWLES ELECTRONICS
ITASCA, ILLINOIS U.S.A.

WHEN TEST LIMITS ARE USED TO ESTABLISH INCOMING INSPECTION ACCEPTANCE/REJECTION CRITERIA, CORRELATION OF TEST EQUIPMENT WITH KNOWLES IS ALSO REQUIRED FOR ELIMINATION OF EQUIPMENT AND TEST METHOD VARIATION

TITLE: **RECEIVER**
PERFORMANCE SPECIFICATION

EC-23098-000
SHT 2.1

DR. BY	DATE
CRG	11-14-05
CK. BY	DATE
GJP	11-22-05
APP. BY	DATE
GJP	11-22-05